

Weatherly Aircraft Company

620-B

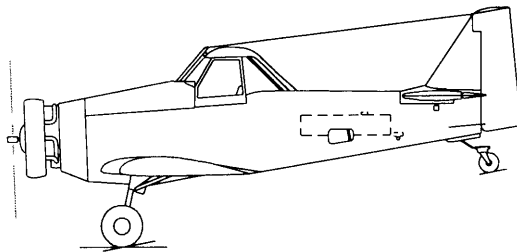
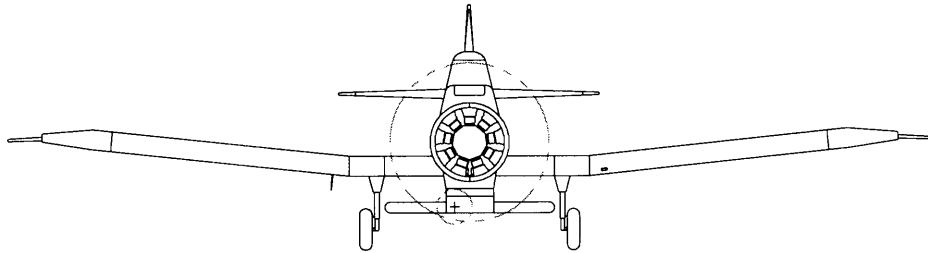
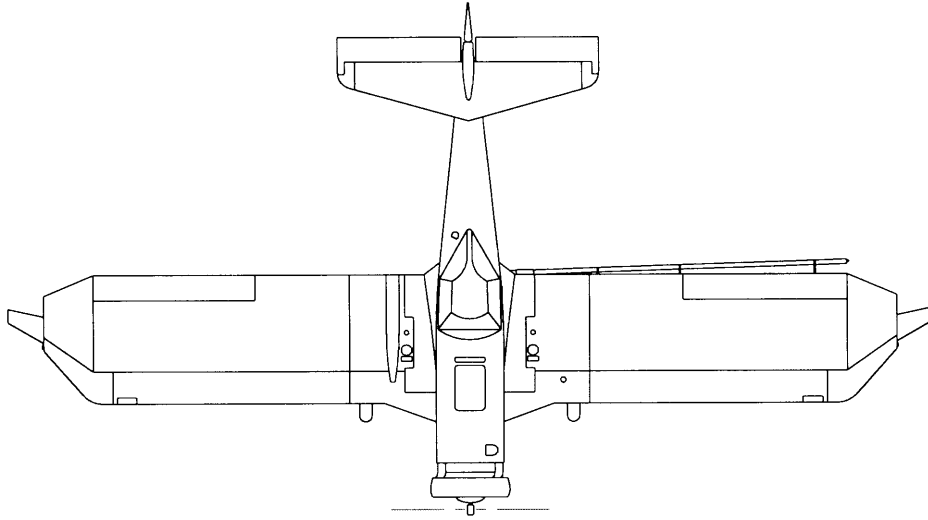

Empty Weight	2,840 lbs (1,288 kg)
Certified Gross Weight	4,000 lbs (1,814.4 kg)
Wing Span	46 ft 8 in (14.22 m)
Length	26 ft 9 in (8.15 m)
Height	8 ft 0 in (2.44 m)
Wing Area	277 sq ft (25.73 sq m)
Main Gear Tread Width	10 ft 6 in (3.2 m)

TABLE I

STANDARD TORQUE VALUES FINE-THREAD SERIES		
THREAD SIZE	TENSION-TYPE NUTS (AN365 & AN310)	SHEAR-TYPE NUTS (AN364 & AN320)
8-36	12-15 in. lbs.	7-9 in. lbs.
10-32	20-25	12-15
1/4-28	50-70	30-40
5/16-24	100-140	60-85
3/8-24	160-190	95-110
7/16-20	450-500	270-300
1/2-20	480-690	290-410
9/16-18	800-1000	480-600
5/8-18	1100-1300	600-780
3/4-16	2300-2500	1300-1500
7/8-14	2500-3000	1500-1800
1-14	3700-5500	2200-3300
1-1/8-12	5000-7000	3000-4200
1 1/4-12	9000-11000	5400-6600

TABLE II

SERVICE OILS & GREASE		
Grease, Multi-purpose	MIL-G-24139	Aeroshell 6
Engine Oil	SAE 25W60 MULTIGRADE	AVIATION OIL
Brake System Fluid	MIL-H-5606	Aeroshell Fluid 4
Landing Gear Oil	SAE 10	or Shell Tellus #29

TABLE III

INSTRUMENT MARKINGS			
INSTRUMENT	GREEN ARC	YELLOW ARC	RED LINE
Tachometer	1800-2100	2100-2300	2300 RPM
Manifold Pressure(AN-1)	20-33"h.g.	33-37 1/2"h.g.	37 1/2" h.g.
Oil Temp.	30°-85°C		93°C
Oil Pressure	50-100 psi		50 & 100 psi
Fuel Pressure	2-6 psi		2 & 6 psi
Cyl. Head Temp.	100°-250°C		288°C
Air Speed	60-140 mph	140-176 mph	176 mph